

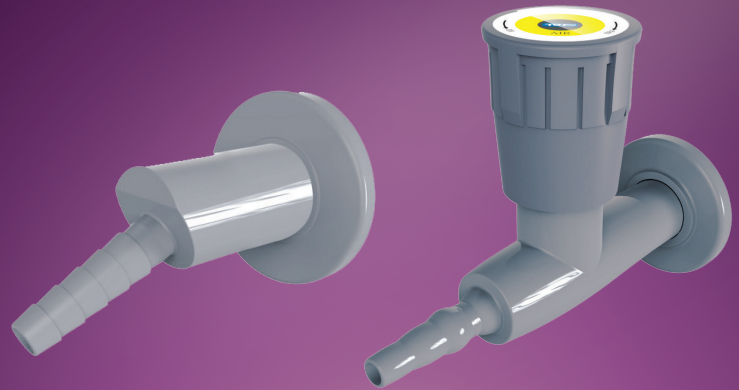

TOPAIR
SYSTEMS

ACCESSORIES CATALOG

TOPAIR



Gas tap with remote valve

Model: FH-GTAP

Model Order Example: FH-GTAP-N

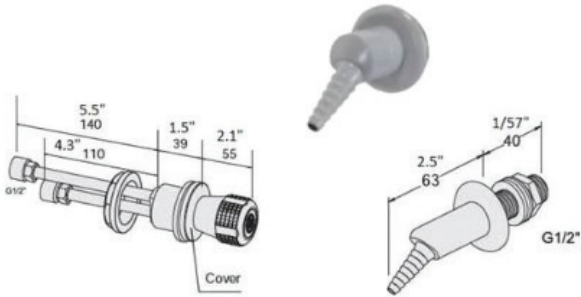

Water/gas tap wall mounted with valve

Model

Water: FH-WM-TAP-W

Gas: FH-WM-TAP-G

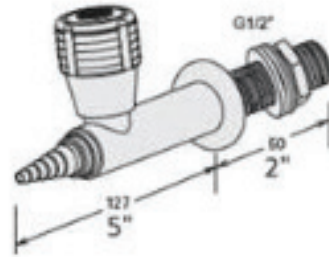

Swan water tap with remote valve

Model: FH-WTAP-SW

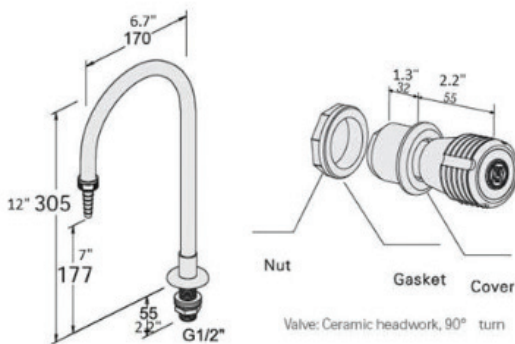

Hot/cold water tap

Model: FH-WTAP-HC

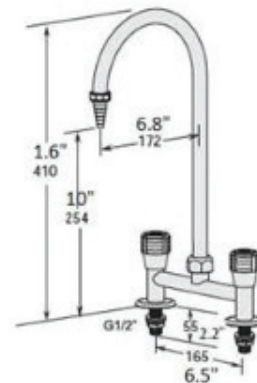

Water tap with remote valve

Model: FH-WTAP

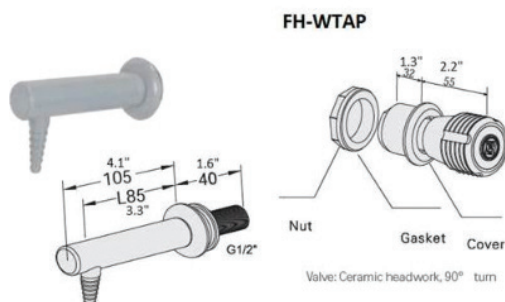





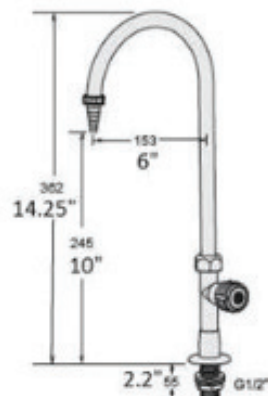











Swan tap worktop mounted with valve

FH-S-TAP



DIN EN 13792:2002 Recommendation Colour Coding of Operating Handles

Type		Handle	Ring	Button	Model
Cold Water		green	green	blue	CW
Hot water		green	green	red	HW
Distilled water		green	white	white	DW
Low pressure steam		green	red	red	S
Vacuum		grey	grey	grey	VAC
Compressed air		blue	blue	yellow	AIR
Nitrogen		blue	green	green	N ₂
Argon		blue	grey	grey	Ar
Helium		blue	grey	white	He
Carbon dioxide		blue	blue	black	CO ₂
Oxygen		blue	blue	blue	O ₂
Hydrogen (burning)		red	red	red	H ₁
Propane/Butane LPG(burning)		yellow	red	yellow	GAS
Butane(burning)		yellow	blue	blue	C ₄ H ₁₀
Propane (burning)		yellow	blue	red	C ₃ H ₈
Acetylene (burning)		yellow	White	green	C ₂ H ₂



TOPAIR
SYSTEMS

Sinks



Square Sink

Part number: FH-KP3B

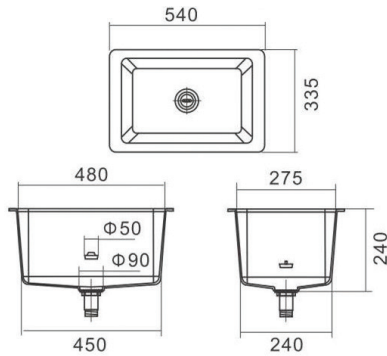

	Length	Width	Height
Outer Diameter	540	335	240
Inner Diameter	480	275	230

Square Sink

Part number: FH-KP3-1B

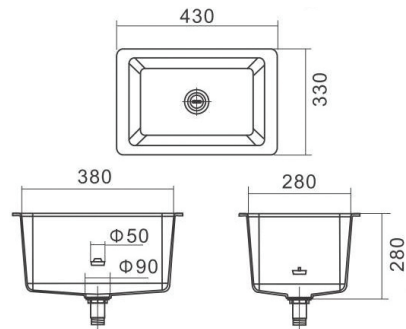

	Length	Width	Height
Outer Diameter	430	330	280
Inner Diameter	380	280	270

Square Sink

Part number: FH-KP1B

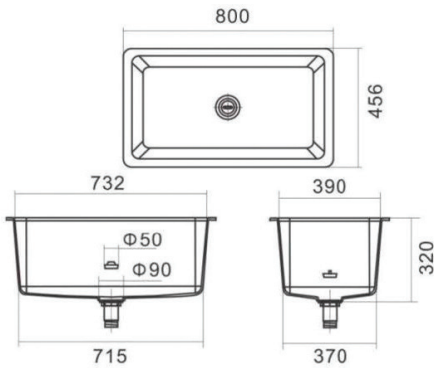

	Length	Width	Height
Outer Diameter	800	456	320
Inner Diameter	732	390	310

Square Sink

Part number: FH-KP2-1

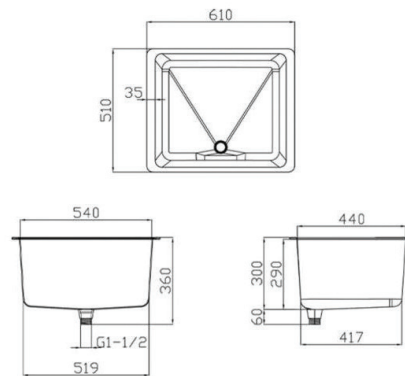

	Length	Width	Height
Outer Diameter	610	510	300
Inner Diameter	540	440	290

Sinks

Round Cup Sink

Part number: FH-KP4-1B

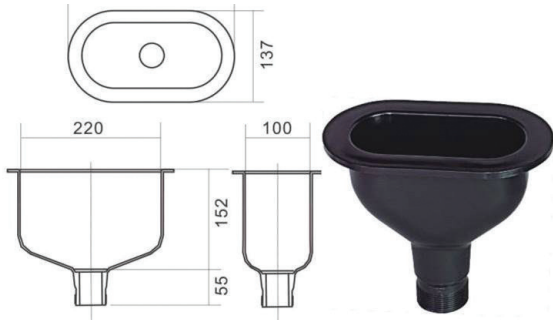

	Length	Width	Height
Outer Diameter	255	137	207
Inner Diameter	220	100	152

Round Cup Sink

Part number: FH-KP4-2B



	Length	Height
Outer Diameter	185	220
Inner Diameter	155	125

Round Cup Sink

Part number: FH-KP4-3B

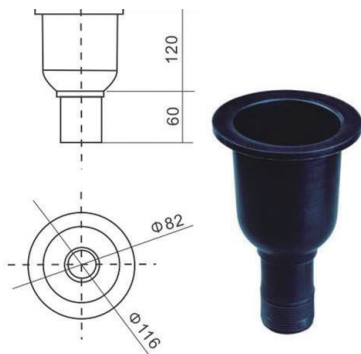

	Length	Height
Outer Diameter	116	180
Inner Diameter	82	120

Water Trap

Part number: FH-BT1

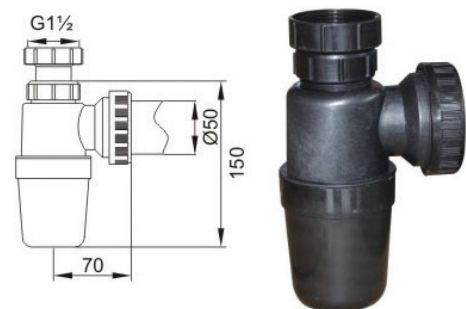

*Stainless Steel Sinks Are Available



Duplex Outlet

Model: FH-SOCKET-DP



Schuko Outlet

Model: FH-SOCKET-SC



British Outlet

Model: FH-SOCKET-T-G



Australian Outlet

Model: FH-SOCKET-T-I



Multination outlet

Model: FH-SOCKET



Model: FH-KIT

Including:

Sink

Model: FH-KP4-1B

Gas Tap

Model: FH-GTAP

Water Tap

Model: FH-WM-TAP

Four Outlets

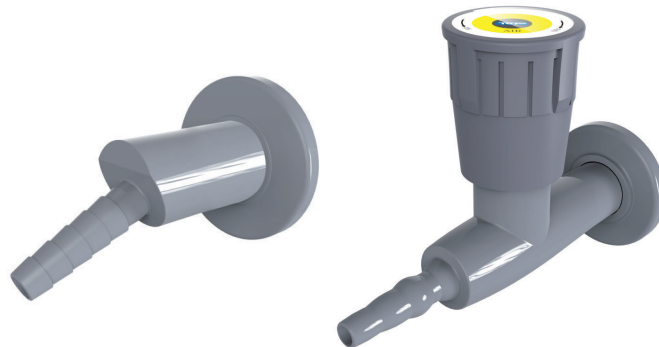

*Illustration *Select your four preferred outlets



TOPAIR
SYSTEMS

Explosion-proof lighting



Model Number	Depth	Width	Length
FH-LI-EX-60	63 mm 28.9 inches	115 mm 4.5 inches	735 mm 2.4 inches
FH-LI-EX-120	63 mm 52.5 inches	115 mm 4.5 inches	1335 mm 2.4 inches

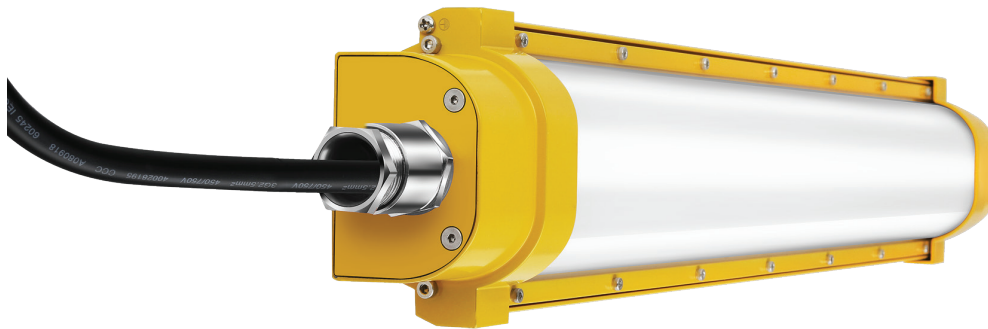

Model: FH-CP

Diameter: 80 mm (3.1 inch)

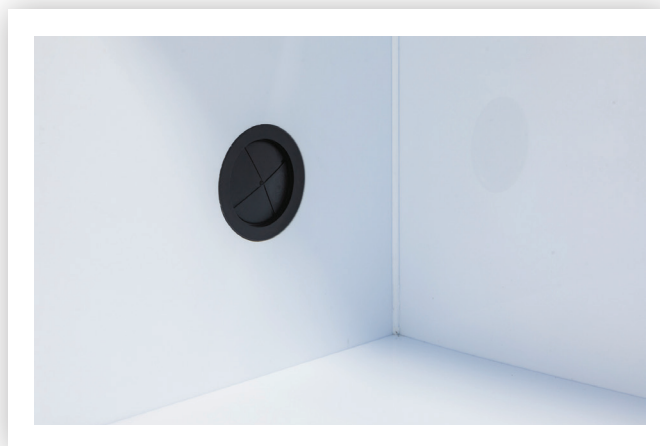



Model Number	Size
FH-SCF-100	W=100 / H=80 cm W=3.9 inches / H=3.1 inches
FH-SCF-120	W=120 / H=80 cm W=4.7 inches / H=3.1 inches
FH-SCF-150	W=150 / H=80 cm W=5.9 inches / H=3.1 inches

A combination of sizes is available



Model: FH-PEG

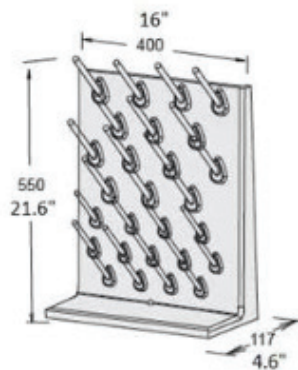

Activated carbon for vapors phase adsorption CF-BS

CF-BS is an activated charcoal that is suitable for the removal of a wide range of organic pollutants in the vapour phase. The predominance of micropores ensures effective removal of low molecular weight contaminants, present in low concentrations.

The extruded form of this product offers exceptional hardness and durability, especially in annular and deep bed adsorption units where loading stress may be high. CF-CR is suitable for use in inert gas purification, for example charcoal dioxide and nitrogen.

Features and Benefits

- High activity product
- Extruded form
- Predominately microporous
- Exceptional product hardness
- Low dust forming properties
- Good resistance to attrition
- Wide range of pellet diameters
- High organic removal capacity
- Versatile adsorbent
- Consistent pressure loss characteristics

Adsorption Capacity Absorption

Selected compounds in air

Compound	Type	Concentration	Capacity
n-Hexane	Aliphatic	10ppmv	9.4
		1000ppmv	17.1
Trichloroethene	Chlorinated	10ppmv	15.2
		1000ppmv	36.7
n-Propanol	Alcohol	10ppmv	14.0
		1000ppmv	33.1
Toluene	Aromatic	10ppmv	12.4
		1000ppmv	25.9

* Multigas filters, designed for use with various materials, are available.

Charcoal Filters

Model Number	Size (cm)	Size (in)
CF-090-CR	90 cm	35 in
CF-120-CR	120 cm	47 in
CF-150-CR	150 cm	59 in
CF-180-CR	180 cm	71 in
CF-200-CR	200 cm	79 in

Specification

CTC adsorption	min. 55%
Moisture content, as packed	max. 5%
Ash content	min. 12%
Hardness	min. 98%

Typical Properties

Surface area	1000m ² /g
Butane adsorption	25%
Apparent density, tapped	470 – 530 kg/m ³
Filling density, loose packed	400 – 450 kg/m ³
Pellet diameter tolerance	±10% dia.

* All the charcoal blends in TopAirSystems filters are made by Jacobi Germany
 * Multigas filters, designed for use with various materials, are available.

Filter Box - Including High-Capacity Charcoal filter

Example of order: FH-FB-6060-CR
 Model: FH-FB-6060

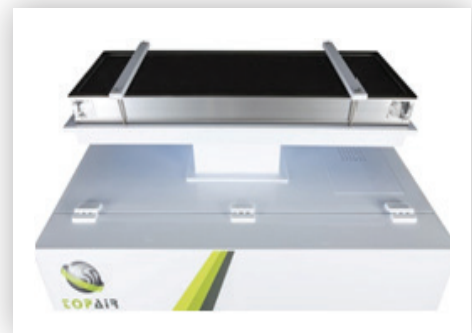

Impregnated Coal Based Activated Charcoal Cf-Fmd

CF-FMD is an impregnated activated charcoal manufactured by steam activation from select grades of anthracite coal. CF-FMD is chemically impregnated. The carefully controlled addition of highly reactive chemical reagents ensures the efficient removal and retention of air borne pollutants including formaldehyde. The activated charcoal is also exceptionally hard and resistant to mechanical breakdown resulting from a unique binding and extrusion process used during manufacturing.

CF-FMD is chromium and halogen free ensuring safe handling and easy disposal by conventional methods.

Features and Benefits

- Chemically impregnated
- Consistent quality
- Exceptional hardness and strength
- Rigorously dedusted
- Maximum formaldehyde loading capacity
- Minimal product degradation giving low pressure drop
- Clean handling at absorber loading and commissioning

Typical Applications

- Synthetic laminate manufacturing
- Laboratory fume hood filters
- Mortuary ventilation systems

Model Number	Size (cm)	Size (in)
CF-090-FMD	90 cm	35 in
CF-120-FMD	120 cm	47 in
CF-150-FMD	150 cm	59 in
CF-180-FMD	180 cm	71 in
CF-200-FMD	200 cm	79 in

Specification

CTC activity (base charcoal)	min. 60%
Moisture content	max. 13%
Total ash content (base charcoal)	max. 12%
Ball-pan hardness	min. 98%
Formaldehyde capacity	min. 10%

Typical Properties

CTC activity (base carbon)	63%
Apparent density	620 kg/m ³
Pellet diameter	± 10% diameter

* All the charcoal blends in TopAirSystems filters are made by Jacobi Germany

* Multigas filters, designed for use with various materials, are available.

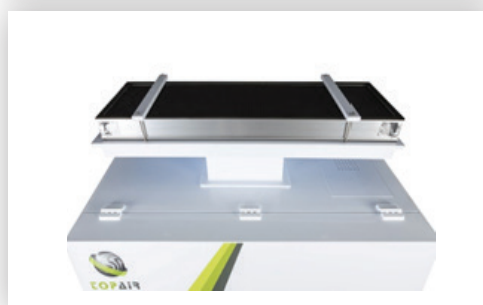

Impregnated Coal Based Activated Charcoal Cf-Bs

CF-BS is a high activity extruded activated charcoal manufactured by steam activation from select grades of anthracite coal. CF-BS is chemically impregnated for the control of inorganic alkali gases, such as ammonia, amines and caustic fumes in vapor phase applications. The careful chemical impregnation allows for a high removal efficiency while maintaining a high capacity for contaminant removal.

For these reasons, CF-BS can be used in a variety of applications, including the protection of critical equipment. CF-BS is manufactured in dedicated production facilities, ensuring a high degree of product consistency and stability.

*Option: Multi-Gas Filter-a blend of 50% acids and 50 % bases charcoal with a good efficiency for both acids and bases

Features and Benefits

- Chemically impregnated
- Consistent quality
- Exceptional hardness and strength
- Rigorously dedusted
- Maximum loading capacity
- Minimal product degradation giving low pressure drop
- Clean handling at absorber loading and commissioning

Typical Applications

- Chemical storage tank venting
- Purification of process gases
- Office air recirculation systems
- Laboratory fume hood filters

Specification

CTC activity (base charcoal)	min. 60%
Moisture content	max. 15%
Total ash content (base charcoal)	max. 15%
Ball-pan hardness	min. 95%
Phosphoric acid content	min. 10%

Typical Properties

Apparent density	620 kg/m ³
Pellet diameter	± 10% diameter

- * All the charcoal blends in TopAirSystems filters are made by Jacobi Germany
- * Multigas filters, designed for use with various materials, are available.

Model Number	Size (cm)	Size (in)
CF-090-BC	90 cm	35 in
CF-120-BC	120 cm	47 in
CF-150-BC	150 cm	59 in
CF-180-BC	180 cm	71 in
CF-200-BC	200 cm	79 in

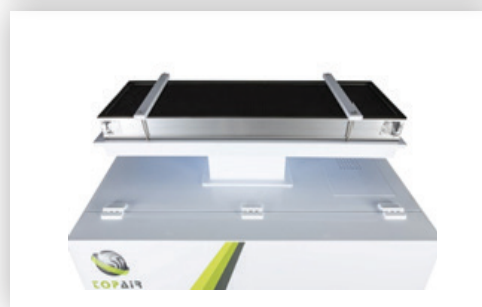

Impregnated coal based activated Charcoal CF-AC

CF-AC is a high activity extruded activated charcoal manufactured by steam activation from select grades of coal. CF-AC is chemically impregnated and thermally treated to allow for the removal of acid gases in oxygen deficient atmospheres.

The carefully controlled dispersion of the reactive chemical reagents ensures the efficient removal and retention of the contaminants while preserving a high adsorption capacity. The activated charcoal is exceptionally hard and resistant to mechanical breakdown.

*Option: Multi-Gas Filter-a blend of 50% acids and 50 % bases carbon with a good efficiency for both acids and bases

Features and Benefits

- Chemically impregnated
- Multi-process manufacture
- Exceptional hardness and strength
- Rigorously dedusted
- Maximum sulfur loading capacity
- Functional in oxygen deficient environments
- Minimal product degradation giving low pressure drop
- Clean handling at absorber loading and commissioning

Typical Applications

- Natural gas purification
- Laboratory fume hood filters
- Catalyst guard bed
- Purification of biogas
- Electronics manufacturing facilities

Model Number	Size (cm)	Size (in)
CF-090-AC	90 cm	35 in
CF-120-AC	120 cm	47 in
CF-150-AC	150 cm	59 in
CF-160-AC	160 cm	63 in
CF-180-AC	180 cm	71 in
CF-200-AC	200 cm	79 in

Specification

CTC activity (base chacoal)	min. 60%
Moisture content	max. 3%
Ball-pan hardness (pellets)	min. 98%
Ball-pan hardness (granular)	min. 90%
Metal oxide content	min. 5.0%

Typical Properties

CTC activity (base carbon)	63%
Apparent density (pellets)	540 kg/m ³
Apparent density (granular)	470 kg/m ³

* All the charcoal blends in TopAirSystems filters are made by Jacobi Germany

* Multigas filters, designed for use with various materials, are available.

The filter series with hot melt technology is a unique family of mini-pleat HEPA and ULPA filters designed to meet the demanding airflow and efficiency requirements of the semiconductor, pharmaceutical, biotech, food processing, and other industries where airborne contaminants must be carefully controlled. These filters combine the right features to provide optimum efficiency while keeping operating costs to a minimum.

The filter series with knife-edge cell sides was designed specifically for gel seal grid systems. With 2", 3", or 4" deep media packs, the filter design reduces resistance and provides the lowest possible pressure drop. Hot melt glue beads maintain pleat separation within the pack while allowing a more compact filter depth than corrugated separators. The media pack is bonded to the sides of the extruded aluminum frame with urethane adhesive, forming an airtight seal. The filter's microglass media is water-resistant and fire-retardant.

The filters are scan-tested at 99.99% efficiency with a non-DOP aerosol to ensure they are free from pinhole leaks. An ULPA (Ultra Low Penetration Air) model is also available, which is additionally laser-tested to 99.9995% at 0.10–0.20 μm .

- Lightweight and compact
- Easy installation – no corrugated separators
- Mini-pleat design features maximum media cleaning potential
- Lowest possible pressure drop reduces operating costs
- Available in a range of cleaning efficiencies

Mini-Pleat Media Pack

- Highest efficiency and lowest possible pressure drop
- Pack depths from 2" to 4"
- Eight pleats per inch allow for the greatest amount of media in the shallowest depth
- Pleat straightness to $\pm 1/4$ "—unmatched by competitors
- Classified under UL 900
- Listed in the Factory Mutual (FM) Approval Guide

Sturdy Construction

Manufactured from borosilicate microfibers, the filter's media is water-resistant and fire-retardant. The media pack is permanently attached to an anodized extruded aluminum frame with a UL-classified urethane adhesive. Frames are available with gasket seal, gel seal, or knife-edge seal for fluid seal grid applications. The series filter with knife-edge cell sides was designed specifically for gel seal grid systems.



Outdoor centrifugal plastic fan

TopAir Systems offers high-quality outdoor centrifugal fans. The roof/side wall fans are weather resistant, built upon on a PVC structure and polypropylene impeller. The motor offers a 3 Phase 200-380V 50Hz power supply, with water protec on level of IP 55. TopAir’s variety of sizes, flows and accessories allows a choice of the best-suited fan for your needs.



Models

Fan Model Product:	RPM	Pressure (PA)	M3/H	Power	Structure	Impeller	Power Supply	Water Resistance	Sound Level	Weight
FHFAN-750	2850	510	2000	750 W	PVC	PP Dia 400 mm W-200 mm	3 Phase 200-380V 50 Hz	IP 55	70 dBA	25 kg
		500	2200							
		490	2400							
		470	2600							
		440	2800							
		420	3000							
		380	3200							
		340	3400							
		300	3600							
FHFAN-1500	2850	510	3600	1500 W	PVC	PP Dia 550 mm W-250 mm	3 Phase 200-380V 50 Hz	IP 55	70 dBA	30 kg
		500	3800							
		490	4000							
		470	4200							
		440	4400							
		420	4600							
		380	4800							
		340	5000							
		300	5200							
FH-FAN-1500300--EXP	2800	510	2000	1500 W	PVC	PP Dia 400 mm W-200 mm	3 Phase 200-380V 50 Hz	IP 55	70 dBA	25 kg
		500	2200							
		490	2400							
		470	2600							
		440	2800							
		420	3000							
		380	3200							
		340	3400							
		300	3600							

Every product arrives with a surface. Choose your preference:

- Stainless Steel 304/316: Durable and corrosion-resistant metal.
- Ceramic: Suitable for high temperatures and highly corrosive environments.
- Epoxy: Effective for use with solvents.
- HPL (High-Pressure Laminate): Resistant to solvents, petrol, and suitable for clean rooms.
- PP (Polypropylene): Resistant to corrosive substances.
- PPS (Polyphenylene Sulfide): Fire-retardant material, effective against corrosives.

Work Surface Material	Available colors	Surface thickness
Stainless Steel	Brushed silver, mirrored silver	1 mm (0.03 inch), 1.2 mm (0.04 inch), 1.5 mm (0.05 inch), 2 mm (0.07 inch)
Epoxy	Gray, white, blue, black	19 mm (0.7 inch)
HPL (High Pressure Laminate)	Gray, black	13 mm (0.5 inch), 16 mm (0.6 inch), 19 mm (0.7 inch)
Polypropylene	Gray, blue, white, black, ivory	8 mm (0.3 inch), 12 mm (0.4 inch), 15 mm (0.5 inch), 20 mm (0.7 inch)
PPS (Polyphenylene Sulfide)	Ivory	8 mm (0.3 inch), 12 mm (0.4 inch)



Some products include a stand as standard; for others, please select your preferred stand

Type	Model	Size (cm)	Size (in)
Metal Stand for the “Proline” Ductless Fume Hood	CF-090-ST	90 cm	35 in
	CF-120-ST	120 cm	47 in
	CF-150-ST	150 cm	59 in
	CF-160-ST	160 cm	65 in
	CF-180-ST	180 cm	71 in
	CF-200-ST	200 cm	79 in
	CF-220-ST	220 cm	87 in
	CF-240-ST	240 cm	94 in
	Metal Stand for the “Valueline” Ductless Fume Hood	VL-CF-090-ST	90 cm
VL-CF-120-ST		120 cm	47 in
VL-CF-150-ST		150 cm	59 in
VL-CF-180-ST		180 cm	71 in
Metal Stand for the “Ecoline” Ductless Fume Hood	ECO-CF-075-ST	75 cm	29 in
	ECO-CF-090-ST	90 cm	35 in
	ECO-CF-120-ST	120 cm	47 in
	Eco-CF-150-ST	150 cm	59 in
Metal Stand for PCR-UV Cabinet	PCR-060-UV-ST	60 cm	23 in
	PCR-090-UV-ST	90 cm	35 in
	PCR-120-UV-ST	120 cm	47 in
Metal Stand for PCR-HEPA Cabinet	PCR-060-HEPA-ST	60 cm	23 in
	PCR-090-HEPA-ST	90 cm	35 in
	PCR-120-HEPA-ST	120 cm	47 in
Metal Stand for Polypropylene “Ecoline” Vertical Laminar Clean Bench	ECO-HC-V090-PP-ST	90 cm	35 in
	ECO-HC-V120-PP-ST	120 cm	47 in
	ECO-HC-V150-PP-ST	150 cm	59 in
	ECO-HC-V180-PP-ST	180 cm	71 in
Metal Stand for Polypropylene “Ecoline” Horizontal Laminar Clean Bench	ECO-HC-H090-PP-ST	90 cm	35 in
	ECO-HC-H120-PP-ST	120 cm	47 in
	ECO-HC-H150-PP-ST	150 cm	59 in
	ECO-HC-H180-PP-ST	180 cm	71 in



Polypropylene Cabinets

Model	Size (cm)	Size (in)
CF-090-BS	90 cm	35 in
CF-120-BS	120 cm	47 in
CF-150-BS	150 cm	59 in
CF-160-BS	160 cm	63 in
CF-200-BS	200 cm	79 in
CF-220-BS	220 cm	87 in
CF-240-BS	240 cm	94 in

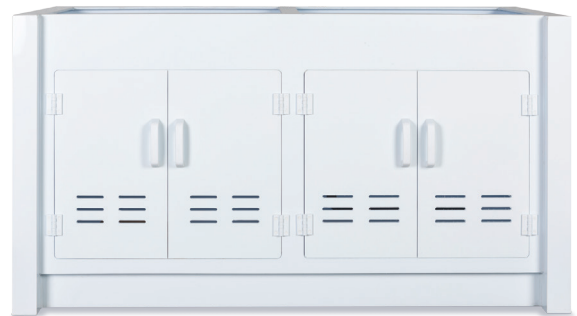

Motorized Stands

Motorized Stand for Biosafety Cabinets	Size (mm)	Size (in)
BO-090-ST-MZ	W x D 915x800 mm	36 x 31.5"
BO-120-ST-MZ	W x D 1220 x 800 mm	48 x 31.5"
BO-150-ST-MZ	W x D 1525 x 800 mm	60 x 31.5"
BO-180-ST-MZ	W x D 1830 x 800 mm	72 x 31.5"

All stands come with a height range of 685 - 1075 mm and a weight capacity of 500 KG





TOPAIR
SYSTEMS

More from TopAir Systems

Emergency Switch

Model: FH-EMS



Metal Fan Wall Rack

Model: FH-WRACK



TOPAIR



TOPAIR
SYSTEMS

www.topairsystems.com

Tel : 1-855-6-TOPAIR / International: +1-855-686-7247

Headquarters: 300 First Avenue, Suite 102, Needham, MA 02494 USA

Email: sales@topairsystems.com

